

HP-120 UNIT

Product Details:

- Standard UL approved 120 VAC models
- Pumps equipped with thermal overload protection



Max Flow (lpm)	120
Max Cont. Operating Max Pressure (PSI)	2.6
Power Consumption (watts)	100
Noise Level (dBa @ 1m.)	42
Weight (lb)	19.8

DIMENSIONS

[Unit: mm(inch)]

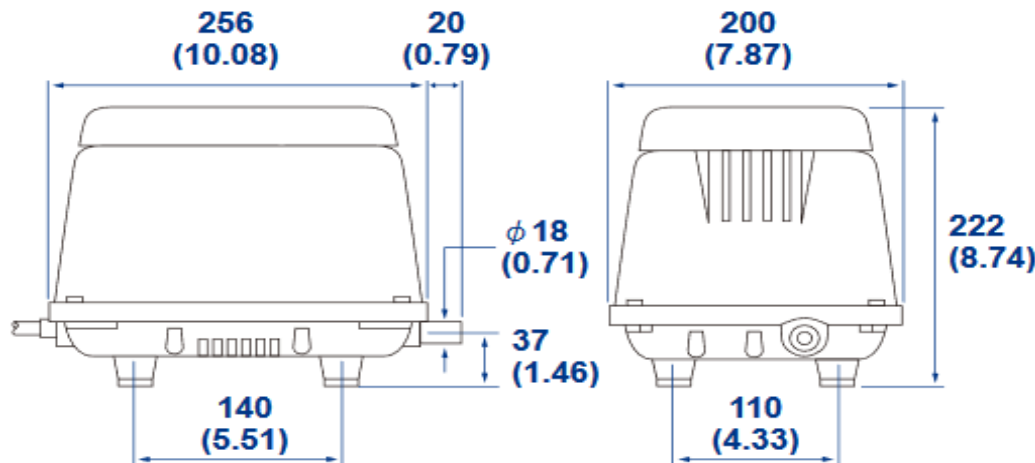

PERFORMANCE CURVES

HP-120

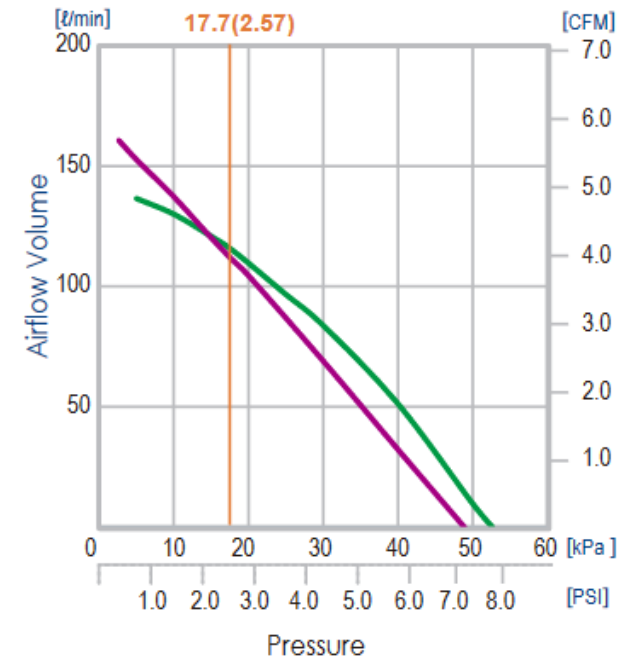

SPECIFICATIONS FOR HIBLOW HP-120 UNIT

- 5.2 cfm (cubic feet per minute) Maximum Air Flow (@ 0 PSI)
- 120 LPM (Liters Per Minute) @ 2.57 PSI
- 4.3 PSI Maximum Continuous Operating Pressure
- 120 VAC, 60 Hz, 1.4A, 100 Watts
- 45 dBA Measured @ 1 Meter
- Dimensions: 10.1" L x 7.9" H x 8.8" H
- Condition: NEW
- Includes Rubber 90 with Hose Clamps
- Includes 1/8" Alarm Connection Fitting

