

HP-150 UNIT

Product Details:

- Available with integral low-pressure alarms for 120 VAC applications
- Standard UL approved 120 VAC models and 230 VAC CE compliant models available
- Pumps equipped with thermal overload protection
- Includes pressure tap location for external Alarm sensor



Max Flow (lpm)	150
Max Cont. Operating Max Pressure (PSI)	2.9
Power Consumption (watts)	125
Noise Level (dBa @ 1m.)	48
Weight (lb)	19.8

DIMENSIONS

[Unit: mm(inch)]

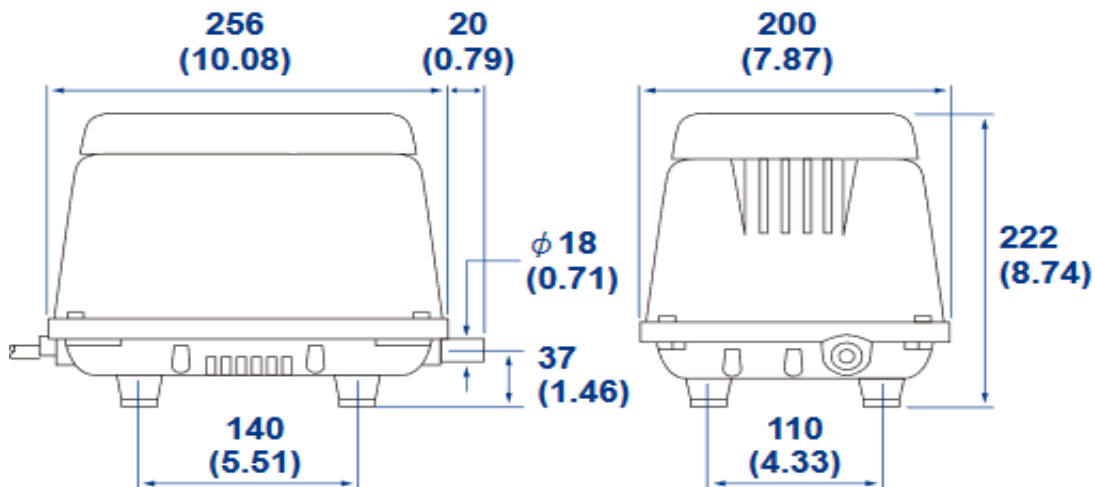

PERFORMANCE CURVES

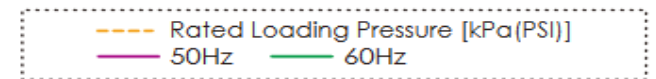

HP-150

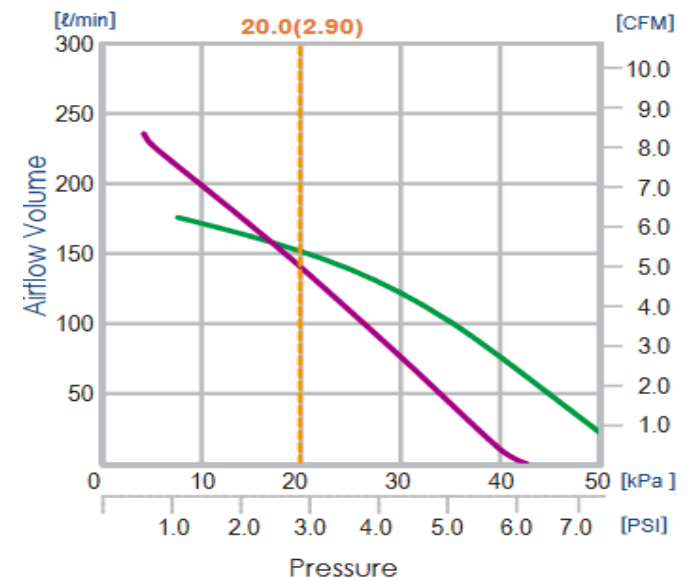

SPECIFICATIONS FOR HIBLOW HP-150 UNIT

- 7.0 cfm (cubic feet per minute) Maximum Air Flow (@ 0 PSI)
- 150 LPM (Liters Per Minute) @ 2.90 PSI
- 4.3 PSI Maximum Continuous Operating Pressure
- 120 VAC, 60 Hz, 2.1A, 150 Watts
- 45 dBA Measured @ 1 Meter
- Dimensions: 10.1" L x 7.9" H x 8.8" H
- Condition: NEW
- Includes Rubber 90 with Hose Clamps
- Includes 1/8" Alarm Connection Fitting
- Fits Many 1000 and 1500 GPD Aerobic Treatment systems (Sizing is Determine by Brand of Aerobic System)

